

GHS 175 x 4 x 6400 C

Product Code :43175464003
Reference No : 01-001

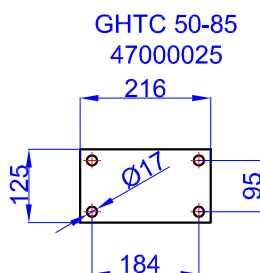

GHCB 60-125-220

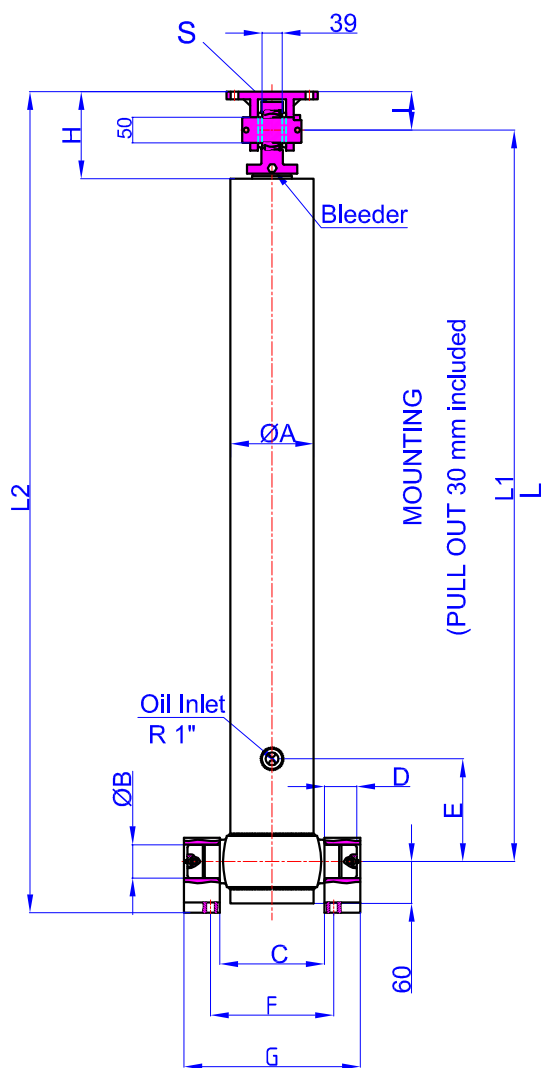
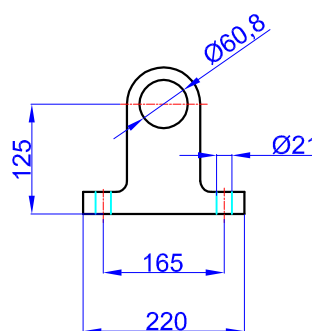

A	: 197 mm
B	: 60 mm
C	: 240 mm
D	: 60 mm
E	: 400 mm
F	: 343 mm
G	: 380 mm
H	: 180 mm
I	: 85 mm
L	: 1950 mm
*L1	: 1980 mm
L2	: 2160 mm
S	: 42 mm

* Inc 30 mm pull out :
tolerance +20 -0

Hard Chromed all stages

Working Pressure : 170 Bar

Max. Working Pressure : 190- Bar

All Cylinder Materials are St 52 Cold Drawn Tubes

Tipping Weight = Weight Body + Payload

STAGE	1	2	3	4	5	6	7	8	TOTAL
EFFECTIVE DIAMETER (mm)	Ø175	Ø154,5	Ø135	Ø116					
STROKE	1600	1600	1600	1600					6400
OIL DISPLACEMENT (L)	40,5	32	24,5	18					115
THRUST AT 170 BAR (TONS)	40	31	24	18					

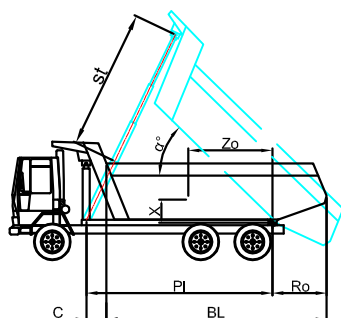

BL (body length)

Ro (rear overhang)

Ycog (vert. pos. centre of gravity)

PI(Pivot length)

$$\alpha^\circ = \text{st} \times 60 / \text{PI}$$

BL	8200			8000			7800		
Ro	200	500	800	200	500	800	200	500	800
α°	45	46	48	46	48	50	47	49	51
Ycog 600	48	51	56	49	53	58	50	54	59
900	51	55	61	52	57	63	53	59	66
1200	55	60	67	56	62	70	58	64	73
st	6150	6056	6080	6133	6160	6166	6110	6125	6120