

GHS 135 x 3 x 3450 C RT	Product Code	:43135334503
	Reference No	:03-001

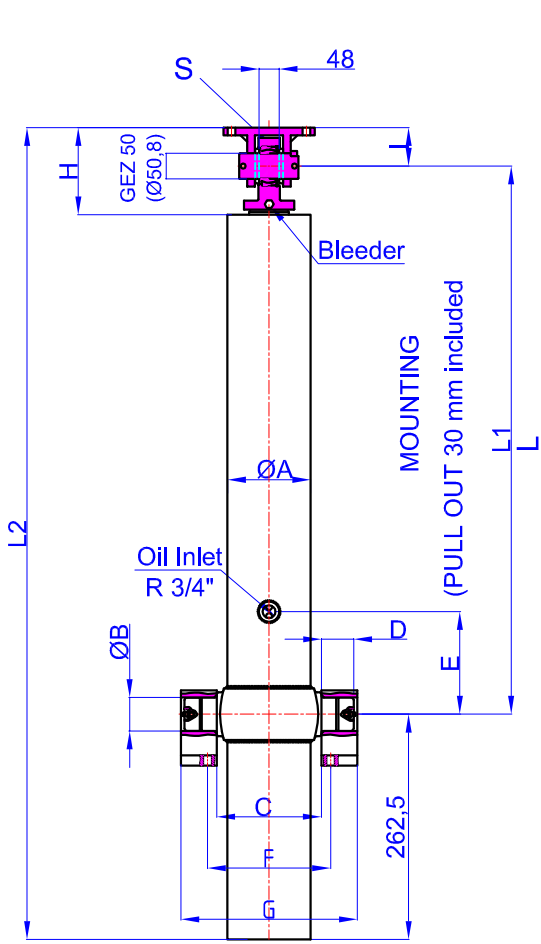

4700028-02-001
(Bracket Kits Top Clevis
GHTC GEZ 50x80)

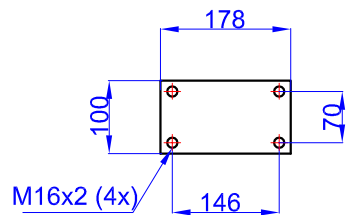

4700057-0001
(Bracket Kits T
60-100-150-22)

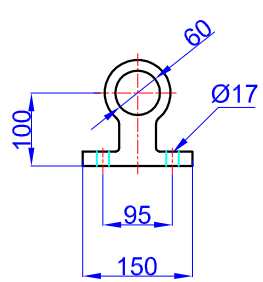

A	:	156	mm
B	:	60	mm
C	:	193	mm
D	:	60	mm
E	:	200	mm
F	:	240	mm
G	:	333	mm
H	:	170	mm
I	:	75	mm
L	:	1245	mm
*L1	:	1275	mm
L2	:	1583	mm
S	:	52	mm

* Inc 30 mm pull out :
tolerance +20 -0

Hard Chromed all stages
 Working Pressure : 135 Bar
 Max. Working Pressure : 150- Bar
 All Cylinder Materials are St 52 Cold Drawn Tubes
 Tipping Weight = Weight Body + Payload

STAGE	1	2	3	4	5	6	7	8	TOTAL
EFFECTIVE DIAMETER (mm)	Ø135	Ø116	Ø98						
STROKE	1150	1150	1150						3450
OIL DISPLACEMENT (L)	17,5	13	9,5						48
135 BAR (TONS)									24 T

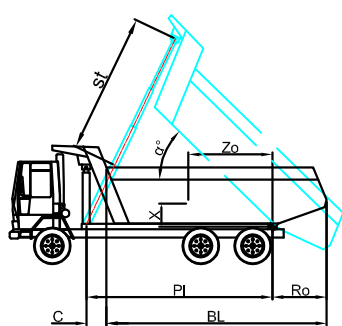

BL (body length)	4400			4300			4200			
Ro (rear overhang)	200	400	600	200	400	600	200	400	600	
α°	45	47	49	46	48	51	47	50	52	
Ycog (vert. pos. centre of gravity)	400	33	36	40	33	37	41	34	38	43
PI (Pivot length)	700	37	41	48	37	42	50	37	42	50
	1000	41	48	56	43	50	58	44	52	59
α° = st x 60 / PI	st	3300	3290	3266	3296	3280	3315	3290	3333	3293