

GHS 135 x 3 x 3720 C RT

Product Code

:43135337203

Reference No

:05-001

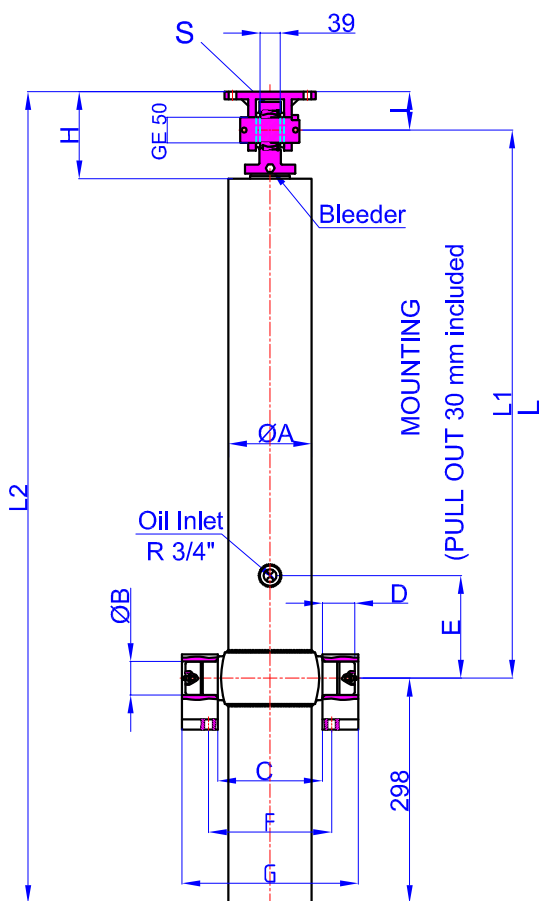

4700020-02-001
(Bracket Kits Top Clevis
GHTC GE 50x75)

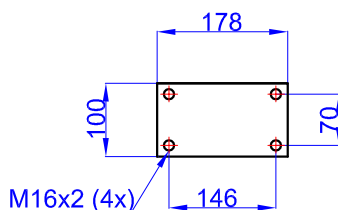

4700057-0001
(Bracket Kits T
60-100-150-22)

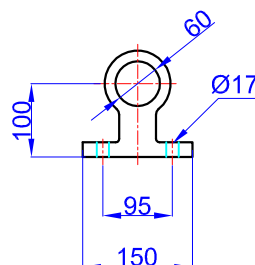

A	:	156	mm
B	:	60	mm
C	:	193	mm
D	:	60	mm
E	:	200	mm
F	:	240	mm
G	:	333	mm
H	:	170	mm
I	:	75	mm
L	:	1310	mm
*L1	:	1340	mm
L2	:	1682	mm
S	:	42	mm

* Inc 30 mm pull out :
tolerance +20 -0

Hard Chromed all stages

Working Pressure : 135 Bar

Max. Working Pressure : 150- Bar

All Cylinder Materials are St 52 Cold Drawn Tubes

Tipping Weight = Weight Body + Payload

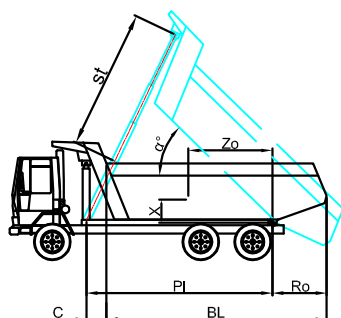

STAGE	1	2	3	4	5	6	7	8	TOTAL
EFFECTIVE DIAMETER (mm)	Ø135	Ø116	Ø98						
STROKE	1240	1240	1240						3720
OIL DISPLACEMENT (L)	19	14	10,5						52
THRUST AT 135 BAR (TONS)									24

BL (body length)

Ro (rear overhang)

Ycog (vert. pos.
centre of gravity)

PI(Pivot length)

$$\alpha^\circ = \frac{st \times 60}{PI}$$

	4700	4600	4500
BL	4700	4600	4500
Ro	200	400	600
α°	45	47	50
Ycog			
400	33	36	39
700	36	40	46
1000	40	46	54
st	3525	3525	3583
	3526	3593	3570
	3525	3583	3621